

# STANDARD HORIZON

HX290E

Floating Marine Transceiver

---

## Owner's Manual

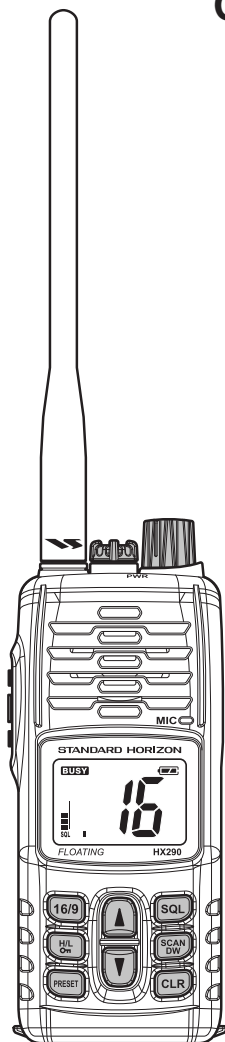

**VERTEX STANDARD CO., LTD.**

# TABLE OF CONTENTS

<b>QUICK REFERENCE GUIDE .....</b>	<b>3</b>
<b>1. GENERAL INFORMATION .....</b>	<b>4</b>
1.1 INTRODUCTION .....	4
1.2 RF EXPOSURE SAFETY STATEMENT .....	4
<b>2. ACCESSORIES .....</b>	<b>5</b>
2.1 PACKING LIST .....	5
2.2 OPTIONS .....	5
<b>3. ABOUT THIS RADIO .....</b>	<b>6</b>
3.1 ABOUT THE VHF MARINE BAND .....	6
3.2 ABOUT WATER RESISTANCE .....	6
3.3 DISTRESS AND HAILING (CHANNEL 16) .....	6
3.4 CALLING ANOTHER VESSEL (CHANNEL 16 OR 9) .....	7
3.5 OPERATING ON CHANNEL 13 .....	8
3.6 OPERATING ON CHANNEL 67 .....	8
3.7 SIMPLEX/DUPLEX CHANNEL USE .....	8
<b>4. GETTING STARTED .....</b>	<b>10</b>
4.1 RADIO CARE .....	10
4.2 BELT CLIP INSTALLATION AND REMOVAL .....	10
4.3 BATTERIES AND CHARGERS .....	11
4.3.1 BATTERY SAFETY .....	11
4.3.2 BATTERY INSTALLATION / REMOVAL .....	12
4.3.3 BATTERY CHARGING .....	13
<b>5. CONTROLS AND INDICATORS .....</b>	<b>14</b>
5.1 CONTROLS AND SWITCHES .....	14
5.2 LCD INDICATORS .....	17
<b>6. BASIC OPERATION .....</b>	<b>18</b>
6.1 PROHIBITED COMMUNICATIONS .....	18
6.2 INITIAL SETUP .....	18
6.3 RECEPTION .....	18
6.4 TRANSMISSION .....	19
6.4.1 TRANSMIT TIME-OUT TIMER (TOT) .....	19
6.5 INTERNATIONAL, CANADIAN, AND USA CHANNELS .....	20
6.6 KEYPAD LOCKING .....	20
6.7 PRESET CHANNELS (0 ~ 9): INSTANT ACCESS .....	21
6.7.1 PROGRAMMING .....	21
6.7.2 OPERATION .....	21
6.8 SCANNING .....	22
6.8.1 SELECTING THE SCAN TYPE .....	22
6.8.2 PROGRAMMING SCAN MEMORY .....	23
6.8.3 MEMORY SCANNING (M-SCAN) .....	23
6.8.4 PRIORITY SCANNING (P-SCAN) .....	23
6.9 DUAL WATCH .....	24
<b>7. ATIS SETUP .....</b>	<b>26</b>
7.1 ATIS CODE PROGRAMMING .....	26
7.2 ATIS CH GROUP .....	27
<b>8. MENU ("SET") MODE .....</b>	<b>28</b>
<b>9. MAINTENANCE .....</b>	<b>30</b>
9.1 GENERAL .....	30
9.2 REPLACEMENT PARTS .....	30
9.3 TROUBLESHOOTING CHART .....	31
<b>10. VHF MARINE CHANNEL ASSIGNMENT .....</b>	<b>32</b>
<b>11. INSTALLATION OF OPTION .....</b>	<b>36</b>
11.1 FBA-42 ALKALINE BATTERY CASE .....	36
<b>12. SPECIFICATIONS .....</b>	<b>37</b>
12.1 GENERAL .....	37
12.2 TRANSMITTER .....	37
12.3 RECEIVER .....	37

# QUICK REFERENCE GUIDE

This transceiver is equipped with the E2O (Easy-To-Operate) system. You can do the basic operation in numerical order of the illustration below.

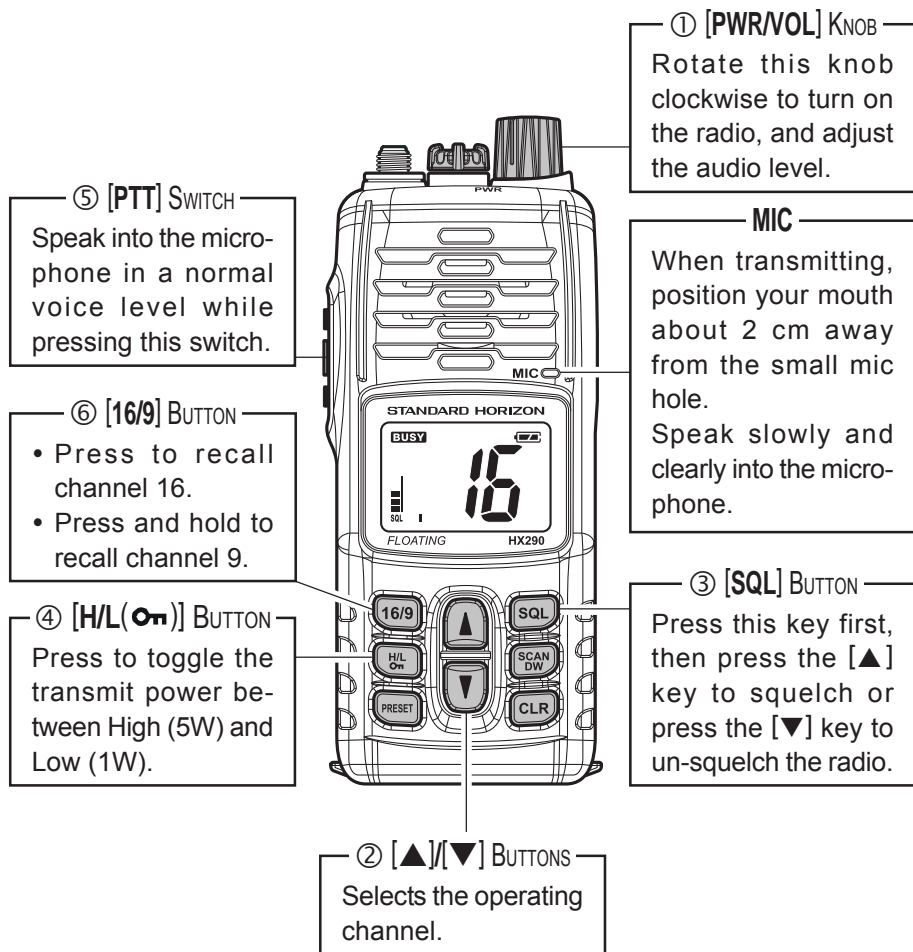

## NOTE

For additional details, refer to the section "5. CONTROLS AND INDICATORS".

# 1. GENERAL INFORMATION

## 1.1 INTRODUCTION

Congratulations on your purchase of the **HX290E**! The **HX290E** is a JIS-8/IPX8\* Submersible Floating 5-Watt portable two way marine transceiver. The transceiver has all allocated International, Canadian, or US channels. It has emergency channel 16 which can be immediately selected from any channel by pressing the  key.

The **HX290E** includes the following features: 10 Programmable Preset Channels, Memory, Priority, Dual Watch Scanning, easy-to-read large LCD display, EEPROM memory back-up, Battery Life displayed on LCD, Glow-In-The-Dark strip, and a transmit Time-Out Timer (TOT).

The **HX290E** transmitter provides a full 5 Watt of transmit power and also is selectable to 1 Watt to assist the user in ensuring maximum battery life.

※JIS-8/IPX8: 1.5 m for 30 minutes

## 1.2 RF EXPOSURE SAFETY STATEMENT

Your wireless handheld portable transceiver contains a low power transmitter. When the Push-to-Talk (PTT: ) button is pushed, the transceiver sends out radio frequency (RF) signals.

This device is authorized to operate at a maximum duty factor not to exceed 2:1 (this corresponds to 50% transmission time and 50% reception time), but normal usage should not exceed 3:1 (25% transmission time and 75% reception/standby time).

This transmitter and its antenna must maintain a separation distance of at least 2 cm from your face. Speak in a normal voice, with the antenna pointed up and away from the face at the required separation distance.

Use only the supplied antenna. Unauthorized antennas, modifications, or attachments could damage the transmitter.

### Attention in case of use

This transceiver works on frequencies which are not generally permitted. For frequency allocation, apply for a licence at your local spectrum management authority. For actual usage contact your dealer or sales shop in order to get your transceiver adjusted to the allocated frequency range.

List of the practicable area						
AUT	BEL	BGR	CYP	CZE	DEU	DNK
ESP	EST	FIN	FRA	GBR	GRC	HUN
IRL	ITA	LTU	LUX	LVA	MLT	NLD
POL	PRT	ROM	SVK	SVN	SWE	CHE
ISL	LIE	NOR				

## 2. ACCESSORIES

### 2.1 PACKING LIST

When the package containing the transceiver is first opened, please check it for the following contents:

- **HX290E** Transceiver
- **CAT460** Antenna
- **FNB-110LI** 7.4 V, 1170 mAh Li-Ion Battery Pack
- **CD-52** Charger Cradle for **HX290E**
- **PA-48C/U**\* 230VAC Wall Charger for **CD-52**
- **CLIP-22** Belt Clip
- Hand Strap
- Owner's Manual
- Warranty Card

### 2.2 OPTIONS

- ① **MH-73A4B** Speaker/Microphone
- ② **MH-57A4B** Mini Speaker/Microphone
- ③ **VC-24** VOX Headset
- ④ **VC-27** Earpiece/Microphone
- ⑤ **CN-3** Radio-to-Ship's Antenna Adapter
- ⑥ **CD-52** Charger Cradle
- ⑦ **FNB-110LI** 7.4 V, 1170 mAh Li-Ion Battery Pack
- ⑧ **FBA-42** Alkaline Battery Case
- ⑨ **PA-48B/C/U**\* AC Wall Charger for the **CD-52**

\*: "B" suffix is for use with 120 VAC (Type-A plug), "C" suffix is for use with 230 VAC (Type-C plug), and "U" suffix is for use with 230 VAC (Type-BF plug).

**Note:** Before operating the **HX290E** for the first time, it is recommended that the battery be charged. Please see section "4.3.3 BATTERY CHARGING" for details.

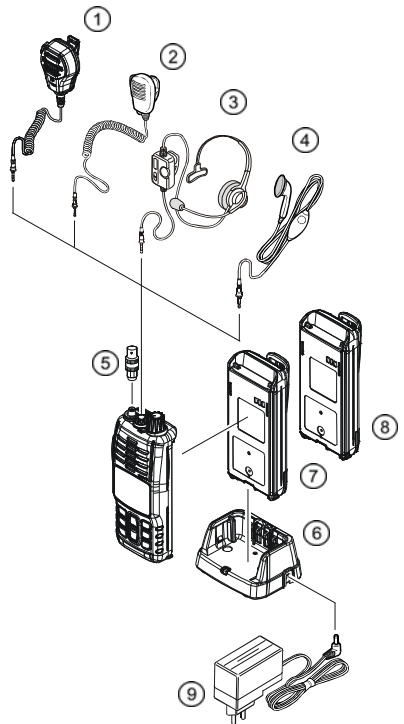

## 3. ABOUT THIS RADIO

### 3.1 ABOUT THE VHF MARINE BAND

The radio frequencies used in the VHF marine band lie between 156 and 158 MHz. The marine VHF band provides communications over distances that are essentially “Line of sight” Actual transmission range depends much more on antenna type, gain and height than on the power output of the transmitter. On a fixed mount 25 W radio transmission expected distances can be greater than 24 km, for a portable 5 W radio transmission the expected distance can be greater than 8 km in “Line of sight”.



The use of Marine VHF radio is governed by regulation and local laws. Use by unauthorized persons is not permitted and is subject to fines and confiscation if convicted. This is especially true when the radio is used on land in a non marine environment where because of location or propagation anomalies especially during the summer, the transmission may cause interference with a search and rescue operation or contribute to a marine collision between passing ships. For VHF marine channel assignments refer to Page 33 Section 10.

### 3.2 ABOUT WATER RESISTANCE

Water resistance of the transceiver is ensured only when the battery pack is attached to the transceiver and **MIC/SP** cap is installed in the **MIC/SP** jack.

### 3.3 DISTRESS AND HAILING (CHANNEL 16)

Channel 16 is known as the Distress and Calling Channel. An emergency may be defined as a threat to life or property. In such instances, be sure the transceiver is on and set to “Channel 16”. Then use the following procedure:

1. Press the **PTT** (Push-To-Talk: ) switch and say “**Mayday, Mayday, Mayday**. This is \_\_\_\_\_, \_\_\_\_\_, \_\_\_\_\_” (your vessel’s name).
2. Then repeat once: “**Mayday, \_\_\_\_\_**” (your vessel’s name).
3. Now report your position in latitude/longitude, or by giving a true or magnetic bearing (state which) to a well-known landmark such as a navigation aid or geographic feature such as an island or harbour entry.
4. Explain the nature of your distress (sinking, collision, aground, fire, heart attack, life-threatening injury, etc.).
5. State the kind of assistance your desire (pumps, medical aid, etc.).
6. Report the number of persons aboard and condition of any injured.
7. Estimate the present seaworthiness and condition of your vessel.
8. Give your vessel’s description: length, design (power or sail), color and other distinguishing marks. The total transmission should not exceed 1 minute.
9. End the message by saying “**OVER**”. Release the **PTT** () switch and listen.

10. If there is no answer, repeat the above procedure. If there is still no response, try another channel.

### 3.4 CALLING ANOTHER VESSEL (CHANNEL 16 OR 9)

Channel 16 may be used for initial contact (cailing) with another vessel.

However, its most important use is for emergency messages. This channel must be monitored at all times except when actually using another channel.

It is monitored by European Coast Guards and by other vessels. Use of channel 16 for cailing must be limited to initial contact only. Calling should not exceed 30 seconds, but may be repeated 3 times at 2-minute intervals. In US waters channel 9 may be used as an alternative calling channel for non-emergency communications. When cailing on channel 9, the calling time should not exceed 30 seconds but may be repeated 3 times at 2-minute intervals.

Prior to making contact with another vessel, refer to the channel charts in this manual, and select an appropriate channel for communications after initial contact. For example, Channels 68 and 69 of the UK VHF Charts are some of the channels available to non-commercial (recreational) boaters. Monitor your desired channel in advance to make sure you will not be interrupting other traffic, and then go back to either channel 16 or 9 for your initial contact.

When the cailing channel (16) is clear, state the name of the other vessel you wish to call and then “**this is**” followed by the name of your vessel and your Station License (Call Sign). When the other vessel returns your call, immediately request another channel by saying “**go to**”, the number of the other channel, and “**over**”. Then switch to the new channel. When the new channel is not busy, call the other vessel.



After a transmission, say “**over**”, and release the **PTT** (Push-To-Talk:  switch). When all communication with the other vessel is completed, end the last transmission by stating your Call Sign and the word “**out**”. Note that it is not necessary to state your Call Sign with each transmission, only at the beginning and end of the contact.

Remember to return to Channel 16 when not using another channel.

### 3.5 OPERATING ON CHANNEL 13

Channel 13 is used at docks, bridges and for maneuvering in port. Messages on this channel must concern navigation only, such as meeting and passing in restricted waters. In emergencies and when approaching blind river bends, High power is allowed. Pressing the  key will change the power output from Low Power (1 Watt) to High (5 Watts). When you change from this channel then return to it, low power will be automatically selected.

### 3.6 OPERATING ON CHANNEL 67

When channel 67 is used for navigational bridge-to-bridge traffic between ships, High power may be used temporarily (in the USA band) by pressing the  key. When the PTT () switch is released, the transceiver will revert to low power.

### 3.7 SIMPLEX/DUPLEX CHANNEL USE

Refer to the section “9. VHF MARINE CHANNEL ASSIGNMENT” for instructions on use of simplex and duplex channels.

#### NOTE

All channels are factory-programmed in accordance with FCC, Industry Canada, and International regulations. The mode of operation cannot be altered from simplex to duplex or vice-versa. Simplex (ship to ship) or duplex (marine operator) mode is automatically activated, depending on the channel and whether the International, USA, or Canadian operating band is selected.

#### IMPORTANT NOTICE

Please follow these cautions to prevent hearing damage:

- Always adjust the audio level of the transceiver to the minimum before connecting the **VC-24** VOX Headset or **VC-27** Earpiece/Microphone to the transceiver.
- Use the **VC-24** VOX Headset and **VC-27** Earpiece/Microphone at as low a volume as possible for existing conditions.
- Slowly adjust the **VOL** knob when increasing the audio level.





## 4. GETTING STARTED

### 4.1 RADIO CARE

#### CAUTION

Before following the instructions below, insure the battery pack is in place and firmly connected. Care must be taken if the radio was dropped and a close inspection may be needed to insure the radio case and gaskets are in adequate condition.

The design of the **HX290E** allows water to enter between the radio and the battery pack, however waterproof performance is not compromised.

After using the **HX290E** in salt water environment is recommended to clean the radio with fresh water by rinsing the battery and radio (separately) under a sink facet or by dunking in a fresh water. After washing, use a soft cloth to thoroughly dry all parts of the radio and battery.

This will keep the radio parts and the battery clean and in top operating condition.

### 4.2 BELT CLIP INSTALLATION AND REMOVAL

- ❑ To install the Belt Clip: align the Belt Clip to the groove of the Battery pack, then press the Belt Clip downward until it locks in place with a **“Click.”**
- ❑ To remove the Belt Clip: press the Belt Clip Tab away from the battery pack to unlock the Belt Clip, then slide the Belt Clip upward to remove it.

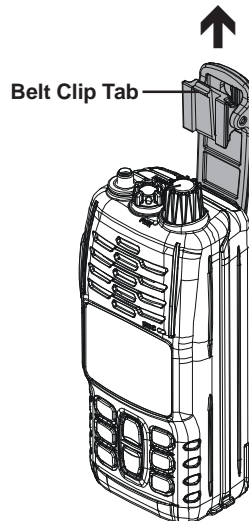
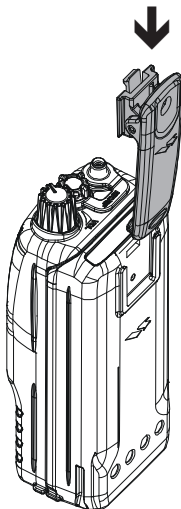

## 4.3 BATTERIES AND CHARGERS

If the radio has never been used, or its charge is depleted, it may be charged by connecting the **CD-52** Charger Cradle with the **PA-48C/U** battery charger. Refer to the section “**4.3.3 BATTERY CHARGING**” for details. The **PA-48C/U** will charge a completely discharged **FNB-110LI** battery pack in about 6 hours.

The **FNB-110LI** is a high performance Li-Ion battery providing high capacity in a compact package.

### CAUTION

To avoid risk of explosion and injury, **FNB-110LI** battery pack should only be removed, charged or recharged in non-hazardous environments.

### 4.3.1 BATTERY SAFETY

Battery packs for your transceiver contain Li-Ion batteries. This type of battery stores a charge powerful enough to be dangerous if misused or abused, especially when removed from the transceiver. Please observe the following precautions:

**DO NOT SHORT BATTERY PACK TERMINALS:** Shorting the terminals that power the transceiver can cause sparks, severe overheating, burns, and battery cell damage. If the short is of sufficient duration, it is possible to melt battery components. Do not place a loose battery pack on or near metal surfaces or objects such as paper clips, keys, tools, etc. When the battery pack is installed on the transceiver, the terminals that transfer current to the transceiver are not exposed. The terminals that are exposed on the battery pack when it is mounted on the transceiver are charging terminals only and do not constitute a hazard.

**DO NOT INCINERATE:** Do not dispose of any battery in a fire or incinerator. The heat of fire may cause battery cells to explode and/or release dangerous gases.

### Battery Maintenance

For safe and proper battery use, please observe the following:

- Battery packs should be charged only in non-hazardous environments;
- Use only STANDARD HORIZON-approved batteries;
- Use only a STANDARD HORIZON approved charger. The use of any other charger may cause permanent damage to the battery.
- Follow charging instructions provided with the chargers.
- Keep the battery contacts clean.

### Battery Storage

Store the batteries in a cool place to maximize storage life. Since batteries are subject to self-discharge, avoid high storage temperatures that cause large self-discharge rates. After extended storage, a full recharge is recommended.

### Battery Recycling

**DO NOT PLACE USED BATTERIES IN YOUR REGULAR TRASH!  
LI-ION BATTERIES MUST BE COLLECTED, RECYCLED OR DISPOSED  
OF IN AN ENVIRONMENTALLY SOUND MANNER.**

The incineration, land filling or mixing of Li-Ion batteries with the municipal solid waste stream is PROHIBITED BY LAW in most areas.

Return batteries to an approved Li-Ion battery recycler. This may be where you purchased the battery.

Contact your local waste management officials for other information regarding the environmentally sound collection, recycling and disposal of Li-Ion batteries.

### 4.3.2 BATTERY INSTALLATION/REMOVAL

- To install the battery pack, hold the transceiver with your left hand, so your palm is over the speaker and your thumb is on the top of the belt clip. Insert the battery pack into the battery compartment on the back of the radio while tilting the Belt Clip outward, then push the bottom side of the battery pack until the battery pack locks with the Battery Pack Latch.
- To remove the battery, turn the radio off. Slide the Battery Pack Latch on the bottom of the radio, then lift up on the bottom of the battery and remove it from the radio.

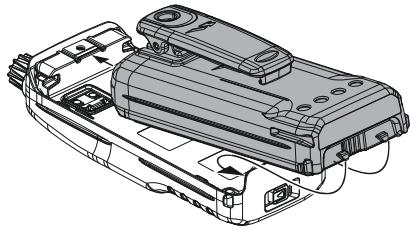

**DO NOT PLACE USED BATTERIES IN YOUR NORMAL  
BIN. LI-ION BATTERIES MUST BE COLLECTED, RE-  
CYCLED OR DISPOSED OF IN AN ENVIRONMENTALLY  
SOUND MANNER.**

*Please contact your local council for information on disposing of  
Li-on Batteries.*

### 4.3.3 BATTERY CHARGING

1. Turn the transceiver off.
2. Insert the DC plug from the **PA-48C/U** into the DC jack on the **CD-52** Charger Cradle side panel, then plug the **PA-48C/U** into the AC line outlet.
3. Insert the **HX290E** (with the battery pack) into the **CD-52**; the antenna should be at the left side when viewing the charger from the front.
4. If the **HX290E** is inserted correctly, the LED indicator will glow red. A fully-discharged pack will be charged completely in approximately 6 hours.
5. When charging is completed, the red LED indicator will change to green. Remove the transceiver from the **CD-52**, and unplug the **PA-48C/U** from the AC line outlet.

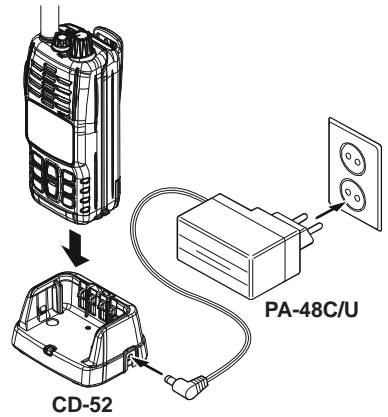

#### CAUTION

- Do not connect an improper battery charger. Use only the **PA-48C/U** with the **CD-52** Charger Cradle.
- The **CD-52** Charger Cradle is NOT designed to be waterproof. Do not attempt to charge in water hazardous locations.

#### NOTE

The **CD-52** Charger Cradle is only designed for the charging of the **HX290E**'s battery, and is not suitable for other purposes. The **CD-52** may contribute noise to TV and radio reception in the immediate vicinity, so we do not recommend its use adjacent to such devices.

## 5. CONTROLS AND INDICATORS

### 5.1 CONTROLS AND SWITCHES

#### NOTE

This section defines each control of the transceiver. For detailed operating instructions, refer to section “6. BASIC OPERATION”. Refer to illustrations for the location of the following controls, switches, and connections.

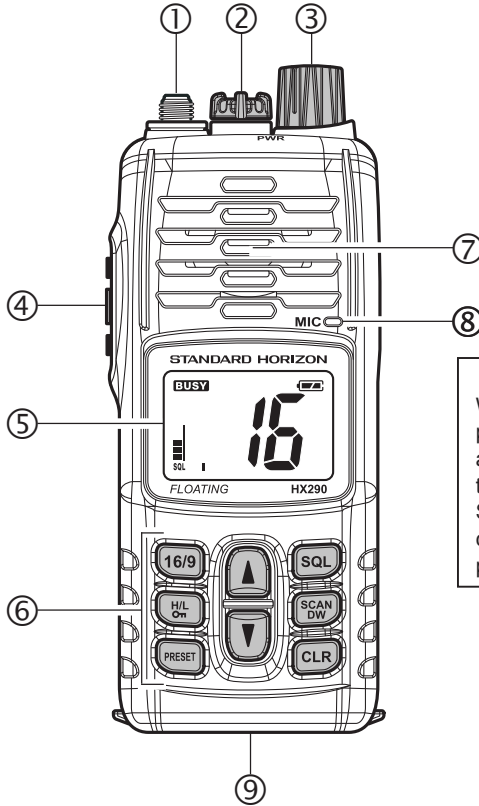

#### NOTE

When transmitting, position your mouth about 2 cm away from the small mic hole. Speak slowly and clearly into the microphone.

① **ANT Jack (Top Panel)**

The supplied **CAT460** flexible antenna is attached here.

② **MIC/SP Jack (Top Panel)**

The jack accepts the optional **MH-73A4B** Speaker/Microphone, **MH-57A4B** Mini Speaker/Microphone, **VC-24** VOX Headset, or **VC-27** Earpiece/Microphone. When this jack is used, the internal speaker and microphone are disabled.

- ③ **POWER Switch/VOLUME Control (VOL)**  
Turns the transceiver on and off as well as adjusts the speakers audio volume.  
Turn this knob clockwise to turn the radio on and increase the speakers audio volume.  
Turn fully counter-clockwise to turn the radio off.
- ④ **PTT (Push-To-Talk: ) Switch**  
When pushed activates the transmitter.
- ⑤ **LCD Display**  
This display shows current operating conditions, as indicated on the page 17.
- ⑥ **Keypad**



 **Key**

Pressing this key immediately recalls channel 16 from any channel location. Holding down this key recalls channel 9. Pressing this key again reverts to the previous selected working channel.



 **Key**

Press this key to toggle the transmitter output power between “High” (5 Watts) and “Low” (1 Watt) power. This key does not function on the “Transmission Inhibited” and “Low power only” channels.

**Secondary use:**

Hold down this key to lock the keypad (except the ,  keys and **PTT** () switch) so that they are not accidentally changed. The “**On**” icon will appear at the bottom right corner on the display, to indicate that the functions are locked. Hold down this key until the “**On**” icon disappears to unlock the radio.

 **Key**

Press this key to recall the user preset memory channels (shown as memory channel number “0” - “9” on the display). Press the  or  key to select the desired preset channel.

Press and hold this key for two seconds to memorize the selected channel into the preset memory.

 **Key**

Press the key momentarily to increase the channel one step. Hold the key down to increase the channel continuously.

**Secondary use:**

Used to adjust the squelch threshold level up after the  key is pressed.



### Key

Press the key momentarily to decrease the channel one step. Hold the key down to decrease the channel continuously.

#### **Secondary use:**

Used to adjust the squelch threshold level down after the  key is pressed.

### Key

Press this key to activate the squelch adjusting mode. Press the  or  key to adjust the squelch threshold level.

Press and hold this key for 3 seconds to open the squelch, allowing you to monitor the operating channel. Release the key to resume normal (quiet) monitoring.

### Key

Starts scanning and priority scanning of programmed channels.

#### **Secondary use:**

Press and hold the  key for two seconds to activate the Dual Watch feature.

### Key

Press to stop the Scan, Priority Scan, or Dual Watch feature.

#### **Secondary use:**

When the  key is held and the  key is pressed, the radio will change the marine band between the International, Canadian, or US channels.

### ⑦ Speaker

The internal speaker is located here.

### ⑧ Microphone

The internal microphone is located here.

When transmitting, position your mouth about 2 cm away from the small mic hole. Speak slowly and clearly into the microphone.

### ⑨ Battery Pack Lock (Bottom side)

Slide the Battery Pack Lock to the “◀” position for battery removal.



## 5.2 LCD INDICATORS

① **“BUSY”** Indicator

This indicator appears when a signal is being received.

② **“TX”** Indicator

This indicator appears during transmission.

③ **“L”** Indicators

This indicator shows the TX output power is “Low” (1 Watt) power.

④ **“On”** Indicator

When the **“On”** icon is shown on the LCD, all keys are disabled except for the PTT (⊗), **SQL**, and **UIC** keys.

⑤ **“”** Battery Indicator

**“”**: Full battery

**“”**: Lower battery

**“”**: Battery is very low

**“”** (Blinking)”: Prepare to charge the battery

⑥ **“”** Indicator

This indicator appears when the Dual Watch is activated.

⑦ **“PRI”** Indicator

This indicator shows the channel is in the transceiver’s “Priority Channel”.

⑧ **“SCN”** Indicator

This indicator appears when the Scan is activated.

⑨ **SQL** Indicator

This indicator shows the squelch level.

⑩ **“P”** Indicator

This indicator shows the channel is in the “Preset Channel”.

⑪ **“U/I/C”** Indicator

These indicators show the “band” of operation for the particular channel. “U” indicates the USA band; “I” indicates the International band; and “C” indicates the Canadian band.

⑫ **“ATIS”** Indicator

This indicator shows the ATIS feature is activated to a current operating band.

⑬ Channel Display

The operating channel is shown on the LCD in both the transmission and reception modes.

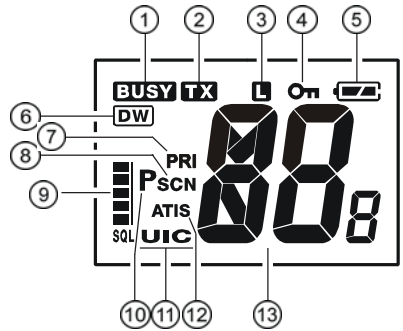

## 6. BASIC OPERATION





### 6.1 PROHIBITED COMMUNICATIONS

- False distress or emergency messages;
- Messages to “any boat” except in emergencies and radio tests;
- Messages to or from a vessel on land;
- Transmission while on land;
- Obscene, indecent, or profane language.

### 6.2 INITIAL SETUP

1. Install the battery pack on the transceiver (see section “4.3.2 BATTERY INSTALLATION/REMOVAL”).
2. Install the antenna onto the transceiver; hold the bottom end of the antenna, then screw it onto the mating connector on the transceiver until it is snug. Do not over-tighten.

### 6.3 RECEPTION



1. Turn the **VOL** knob clockwise to turn the transceiver on.
2. Press the **SQL** key to activate the squelch adjusting mode (The “**SQL**” indicator will blink). Press the **V** key until the “**BUSY**” indicator appears on the display, then press the **SQL** key again. 
3. Turn the **VOL** knob clockwise until the noise or audio from the speaker is at a comfortable level.
4. Press the **SQL** key, then press the **A** key until the random noise disappears. This state is known as the “Squelch Threshold”. 
5. Press the **A** or **V** key to select the desired channel. Refer to the channel chart on page 33 for available channels. 
6. When a signal is received, adjust the **VOL** knob to the desired listening level. The “**BUSY**” indicator on the LCD is displayed indicating that the channel is being used. 

## 6.4 TRANSMISSION

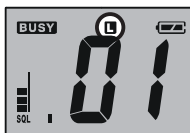
1. Perform “**6.3 RECEPTION**” discussion above.
2. Before transmitting, monitor the channel and make sure it is clear.
3. For communications over short distances, press the  key to select the Low power (1 watt: “**L**” icon appears).





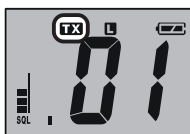
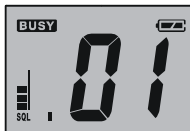

**Note:** Transmitting on Low power prolongs battery life. Low power should be selected whenever possible.

4. If using Low power is not effective, select High power (5 watts: “**H**” icon disappears) by pressing the  key.
5. When receiving a signal, wait until the incoming signal stops before transmitting. The transceiver cannot transmit and receive simultaneously.
6. Press and hold the **PTT** (Push-To-Talk: ) switch to transmit. During transmission, the “**TX**” indicator will appear on the display.
7. Position your mouth about 2 cm away from the mic hole. Speak slowly and clearly into the microphone.
8. When the transmission is finished, release the **PTT** () switch.





### 6.4.1 TRANSMIT TIME - OUT TIMER (TOT)

While the **PTT** () switch is held down, transmission time is limited to 5 minutes. This prevents prolonged (unintentional) transmissions. About 10 seconds before automatic transmitter shutdown, a warning beep will sound from the speaker. The transceiver automatically switches to the receiving mode, even if the **PTT** () switch is held down. Before transmitting again, the **PTT** () switch must first be released. This Time-Out-Timer (TOT) prevents a continuous transmission that would result from an accidentally stuck **PTT** () switch.

#### NOTE

The **PTT** () switch is disabled for 10 seconds after the transceiver automatically switches to the receiving mode by the TOT feature.



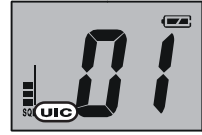

## 6.5 INTERNATIONAL, CANADIAN, AND USA CHANNELS

1. To change from International to Canadian or US Marine Channels, hold down the  key and press the  key. The band will change from International, to Canadian, and to International with each press.
2. “U” appears on the LCD for the USA band, “I” appears for the International band, and “C” appears for the Canadian band
3. Refer to the marine channel charts in section “9 VHF MARINE CHANNEL ASSIGNMENTS” for allocated channels.





## 6.6 KEYPAD LOCKING

In order to prevent accidental channel change, the **HX290E**'s keypad may be locked.

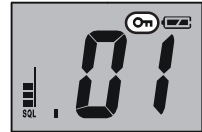
Hold down the  key to lock the keypad (except the ,  keys and **PTT** ( switch) so that they are not accidentally changed. The “” icon will appear on the channel number of the display, to indicate that the functions are locked.













Hold down the  key until the “” icon disappears to unlock the radio.

## 6.7 PRESET CHANNELS (0 ~ 9): INSTANT ACCESS



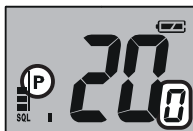

Ten user assigned channels can be programmed for instant access. Pressing the  key activates the user assigned channel bank.

### 6.7.1 PROGRAMMING

1. Select the desired channel to be saved into the Preset Channel bank using the  or  key.
2. Press and hold the  key until the “P” icon and Preset Channel number are flashing, then release the  key.
3. Press the  or  key to select the desired Preset Channel (“0” ~ “9”).
4. Press the  key to program the current channel into the Preset Channel bank.
5. Repeat steps 3 and 4 to program the other channel into the Preset Channels, if desired.
6. To delete a Preset Channel, select the Preset Channel number to be deleted using the  or  key, then press and hold the  key until the Preset Channel number is removed from the display, and the Preset Channel number is changed to the next Preset Channel number.



### 6.7.2 OPERATION

1. Press the  key to change the transceiver to the Preset Channel mode. The “P” icon and Preset Channel number will appear on the display.
2. Press the  or  key to select the desired Preset Channels (“0” through “9”).
3. To exit from the Preset Channel mode, press the  key. The transceiver will revert to the channel you were on prior to switching to the Preset Channel mode.

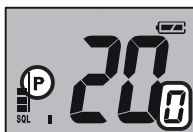

## 6.8 SCANNING

The **HX290E** has two modes for scanning channels. Memory Scan and Priority Scan.

Memory Scan Mode will scan the channels programmed into the Preset instant access channels and programmable Scan Channel Memories.

Priority Scan mode will scan the same channels as Memory Scan Mode and also Channel 16 as the Priority Channel.

When an incoming signal is detected on one of the channels during scan, the transceiver will pause on that channel, allowing you to listen to the incoming transmission. The transceiver will automatically start scanning again after the transmission stops.

### 6.8.1 SELECTING THE SCAN TYPE

1. Turn the transceiver off by rotating the **VOL** knob fully counter-clockwise.
2. Hold down the **[SQL]** key, and then turn on the transceiver while still holding down the **[SQL]** key.
3. “SEt” will appear on the display, indicating the Menu (“Set”) Mode has been activated.
4. Press the **[SQL]** key, repeatedly if necessary to select the Menu item “SC”.
5. Press the **[▲]** or **[▼]** key to select “PS (Priority Scan)” or “MS (Memory Scan)”. The factory default is “PS (Priority Scan)”.
6. After completing your selection, turn the transceiver off and on by rotating the **VOL** knob.
7. See section 6.8.2 for instructions on adding memory channels to the Memory Scan mode and section 6.8.3 on how to initiate a Memory Scan.
8. See section 6.7 for instructions on adding channels to the Preset instant access channels and section 6.8.4 on how to initiate a Priority Scan.

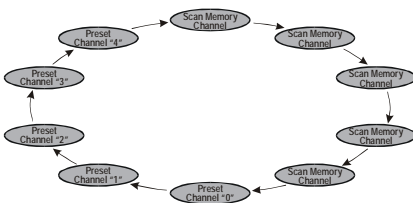
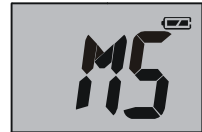
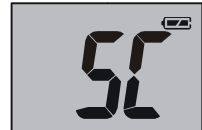

“MEMORY” SCAN

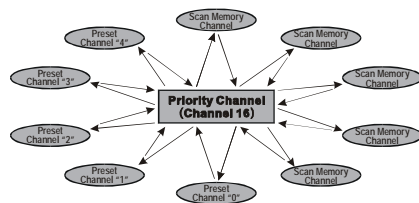

“PRIORITY” SCAN

## 6.8.2 PROGRAMMING SCAN MEMORY

1. Turn the transceiver off by rotating the **VOL** knob fully counter-clockwise.
2. Hold down the **[SQL]** key, and then turn on the transceiver while still holding down the **[SQL]** key.
3. “SEt” will appear on the display, indicating the Menu (“Set”) Mode has been activated.
4. Press the **[SQL]** key, repeatedly if necessary to select the Menu item “SCn”.
5. Press the **[▲]** or **[▼]** key to select desired channel to be scanned, then press the **[SCAN DW]** key. The “SCN” icon appears on the display, which indicates the channel has been selected to the scan channel.
6. Repeat step 5 for all the desired channels to be programmed into scan memory.
7. To DELETE a channel from the list, select the channel then press the **[SCAN DW]** key. The “SCN” icon disappears from the display.
8. When you have completed programming the scan memory, turn the transceiver off and on by rotating the **VOL** knob.

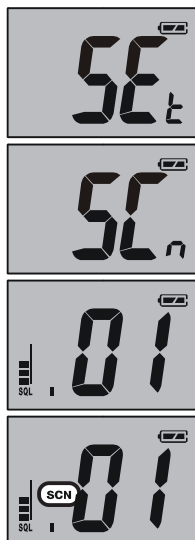

## 6.8.3 MEMORY SCANNING (M-SCAN)

1. Adjust the SQL level until background noise is eliminated by pressing the **[SQL]** key followed by the **[▲]** or **[▼]** key.
2. Press the **[SCAN DW]** key to start scanning channels programmed into scan memory and preset channels. The “SCN” icon will appear at the left of the channel number on the display during scanning.
3. When the **HX290E** receives a transmission, it will stop on the channel until signal disappears, then start scanning again.
4. To stop the scan, press the **[SCAN DW]** key briefly.



## 6.8.4 PRIORITY SCANNING (P-SCAN)

1. Adjust the SQL level until background noise is eliminated by pressing the **[SQL]** key followed by the **[▲]** or **[▼]** key.
2. To start scanning, press the **[SCAN DW]** key. The scan proceeds from the lowest to the highest programmed channel and the Priority Channel (Channel 16). The “PRI” and “SCN” icons will appear at the left of the channel number on the display during scanning.
3. When the **HX290E** receives a transmission on a working channel, it will







stop on the working channel and dual watch to the priority channel until the incoming signal disappears, then start scanning again.

4. When the **HX290E** receives a signal on the Priority channel it will stay on this channel until the incoming signal disappears, then start Priority scanning again.
5. To stop the scan, press the  key briefly.

## 6.9 DUAL WATCH

The Dual Watch feature allows the radio watch the Priority Channel (Channel 16) and one other channel.

1. Select the desired channel you want to Dual watch to the priority channel using the  or  key.
2. Press and hold the  key for two seconds to activate the Dual Watch feature. A “**DW**” icon will appear on the upper left of the display when the Dual Watch feature is activated.
3. When a transmission is received on the “Priority” channel, the radio will stay on the “Priority Channel” until the incoming signal disappears.
4. When the radio receives a transmission on the working channel, the radio will Dual Watch between the working channel and Priority channel.
5. The radio will resume Dual Watch when the incoming signal disappears at the end of the transmission.
6. To stop the Dual Watch feature and return to normal operation, press the  key briefly.

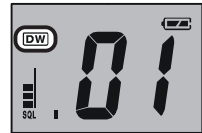





## 7. ATIS SETUP

The **HX290E** supports the ATIS (Automatic Transmitter Identification System) used in Inland waterways in Europe. When enabled ATIS mode transmits a unique ATIS code each time the **PTT** (📡) switch is released at the end of a transmission.

Users should check with their local marine regulatory authority in their country for assistance in obtaining an ATIS code.

### 7.1 ATIS CODE PROGRAMMING

1. Turn the transceiver off by rotating the **VOL** knob fully counter-clockwise.
2. Hold down the **[SQL]** key, and then turn on the transceiver while still holding down the **[SQL]** key.
3. “**SEt**” will appear on the display, indicating the Menu (“Set”) Mode has been activated.
4. Press the **[SQL]** key, repeatedly if necessary to select the Menu item “**Atc**”.
5. Press the **[▲]** or **[▼]** key to select the first number of your ATIS, then press the **[SCAN DW]** key to step to the next number.
6. Repeat step 5 to set your ATIS (ten digits).
7. When finished programming the number, press and hold the **[SCAN DW]** key.
8. Set your ATIS number again.
9. Press and hold the **[SCAN DW]** key to store the ATIS number in memory.
10. After completing your programming, turn the transceiver off and on by rotating the **VOL** knob.

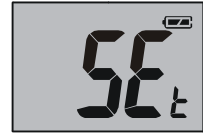

ATIS Number

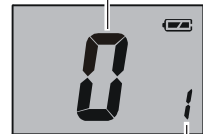

ATIS Digits

ATIS Number (First Entry)

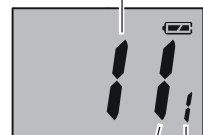







ATIS Number (Second Entry)

ATIS Digits

## 7.2 ATIS CH GROUP

The **HX290E** has the capability to turn on and off the ATIS feature for each channel group.

1. Turn the transceiver off by rotating the **VOL** knob fully counter-clockwise.
2. Hold down the  key, and then turn on the transceiver while still holding down the  key.
3. **SEt** will appear on the display, indicating the Menu (“Set”) Mode has been activated.
4. Press the  key, repeatedly if necessary to select the Menu item **“Ats”**.
5. Press the  or  key to select the channel group (International, Canadian, or USA) you wish to change the setting.
6. Press the  key to select **“On”** or **“Off”**.
7. If you want to set the ATIS feature to another channel group, repeat step 5 and 6.
8. After completing your programming, turn the transceiver off and on by rotating the **VOL** knob.









Channel Group



## 8. MENU (“SET”) MODE

The **HX290E**'s Setup Menu allows a number of the **HX290E** operating parameters to be custom-configured for your operating requirements.

The Setup Menu is easy to activate and set, using the following procedure:

1. Turn the transceiver off by rotating the **VOL** knob fully counter-clockwise.
2. Hold down the  key, then turn on the transceiver while still holding down the  key.
3. “**SEt**” will appear on the display, indicating the Menu (“Set”) Mode has been activated.
4. Press the  key to select the Menu item to be adjusted.
5. Press the  or  key to enable adjustment of the selected Menu item.
6. Press the  key to select the status or value of the Menu item.
7. After completing your adjustment, turn the transceiver off and on by rotating the **VOL** knob.



### LP (LAMP MODE)

**Function:** Selects the Lamp illumination method for the LCD/Keypad.

**Available Values:** on / KEY / oFF

**Default:** KEY

on: Illuminates the LCD/Keypad continuously.

KEY: Illuminates the LCD/Keypad for 5 seconds when any key is pressed.

oFF: Turns off the backlight for the LCD and keys.



### bP (BEEP)

**Function:** Enable/Disable the Keypad beep.

**Available Values:** HI / Lo / oFF

**Default:** HI



### SC (SCAN TYPE)

**Function:** Selects the Scan mode.

**Available Values:** PS (Priority Scan) / MS (Memory Scan)

**Default:** PS (Priority Scan)



### SCn (SCAN CHANNEL)

**Function:** Stores the Scan Channel.

Refer to section “6.8.2 PROGRAMMING SCAN MEMORY” for programming.



### Atc (ATIS CODE)

**Function:** Programming of the ATIS code.

See page 26 for details of the programming.



### Ats (ATIS)

**Function:** Enables/Disables the ATIS (Automatic Transmitter Identification System) feature.

**Available Values:** on / oFF

**Default:** oFF

See page 27 for details of the setting.



## 9. MAINTENANCE

### 9.1 GENERAL

The inherent quality of the solid-state components in STANDARD HORIZON radios will provide many years of continuous use. Take the following precautions to prevent damage to the radio.

- To prevent corrosion of electrical contacts and keep the water resistance, keep the microphone connected or the jack covered at all times.
- Never press the **PTT** (Ⓜ) switch unless an antenna or suitable dummy load is connected to the antenna receptacle.
- Ensure that the input voltage does not exceed the value specified in your Owner's Manual.
- Use only STANDARD HORIZON-approved accessories and replacement parts.

### 9.2 REPLACEMENT PARTS

Occasionally an owner needs a replacement part. These can be ordered from the Standard Horizon/Vertex Standard authorized dealers.

Commonly requested parts, and their part numbers are listed below.

- **CAT460** Antenna: Q3000176
- **VOL** Knob: RA1193900
- **MIC/SP** Rubber Cap: RA1194200
- **MIC/SP** Plastic Cap: RA108700B
- **CLIP-22** Belt Clip: AAH97X001
- Hand Strap: S6000418

## 9.3 TROUBLESHOOTING CHART

SYMPTOM	PROBABLE CAUSE	REMEDY
The <b>[SCAN]</b> key does not start the scan.	No channels memorized.	Enter desired channels into the Preset Channels or Scan Memory Channels. Refer to section 6.8.1 or 6.9.2 of this manual.
	Squelch is not adjusted.	Adjust the squelch to threshold or to the point where noise just disappears. Further adjustment of the squelch control may eliminate incoming signals.
Cannot select between USA, INTL, or Canadian bands.	Proper operation not followed.	HOLD down the <b>[109]</b> key and press the <b>[CLR]</b> key.
Speaker audio is not heard when the <b>[SOL]</b> key is press and held.	Low battery.	Charge battery. Refer to section 4.2.3 of this manual.
	Audio volume level is too low.	Turn the <b>VOL</b> knob clockwise.
Some keys do not operate.	Key Lock is on.	Turn Key Lock off. Refer to section 5.1 of this manual ( <b>[K]</b> key).
Cannot select keylock function.	Proper operation not followed.	Hold down the <b>[K]</b> key for 2 seconds.
Charging indicator on <b>CD-52</b> does not illuminate.	Battery contacts not making contact with the charger cradle.	Contact your Authorised Standard Horizon or Vertex Standard Dealer Service Centre or check <a href="http://www.standardhorizon.co.uk">www.standardhorizon.co.uk</a> for details of the dealers in your area.

## 10. VHF MARINE CHANNEL ASSIGNMENTS

Tables on the following columns list the VHF Marine Channel assignments for U.S.A. and International use. Below are listed some data about the charts.

1. VTS. Where indicated, these channels are part of the U.S. Coast Guard's Vessel Traffic System.
2. Alpha channel numbers, that is, channel numbers followed by the letter A (such as Channel 07**A**) are **simplex** channels on the U.S.A. or Canadian channel assignments whose counterparts in the International assignments are **duplex** channels. International channels do not use "alpha" numbers. If you call the Coast Guard on Channel 16, they will sometimes ask you to "**go to channel 22 Alpha**." This is a channel assigned to U.S.A. and Canadian Coast Guards for handling distress and other calls. If your radio is set for **International** operation you will go to Channel 22 instead of 22**A**, and will not be able to communicate with the Coast Guard. To use Channel 22**A**, your radio must be set for **USA** or **Canada** operation, usually by a U/I/C (USA/International/Canada) control or combination of controls. Channel 22 (without an "A") is an **International** duplex channel for port operations. Some radios indicate an "A" adjacent to the alpha channels on the display; on others "alpha" is not indicated but the proper channel is selected based on the U/I/C setting.
3. Bridge-to-Bridge channels (for example, Channel 13) are for use by bridge operators on inter-coastal waterways and rivers. It is also used by marine vessels in the vicinity of these bridges for navigation and for communicating with the bridge operators. Note that a limit of 1 Watt is specified for these channels.
4. The **S/D** column on the chart indicates either S (simplex) or D (duplex). **Simplex** means transmitting and receiving on the same frequency. Only one party at a time can talk, unlike a telephone. Be sure to say "**over**" and release your microphone push-to-talk switch at the end of each transmission. **Duplex** operation involves the use of one frequency for transmitting and a separate frequency for receiving. On channels specified as duplex on the charts, correct mode of operation is established automatically by your radio when you select a channel; you cannot change the mode. And you still must release the push-to-talk switch after each transmission in order to listen to the radio.
5. Channels normally used by recreational boaters are those that include the term "non-commercial" in the **Channel Use** column of the chart. Some of these are shared with other users and some are used only in certain geographic regions.
6. Marine vessels equipped with VHF radios are required to monitor Channel 16.



VHF MARINE CHANNEL CHART							
CH	U	C	I	S/D	TX	RX	CHANNEL USE
01		X	X	D	156.050	160.650	Public Correspondence (Marine Operator)
01A	X			S	156.050		Port Operation and Commercial. VTS in selected areas
02		X	X	D	156.100	160.700	Public Correspondence (Marine Operator)
03		X	X	D	156.150	160.750	Public Correspondence (Marine Operator)
<b>03A</b>	<b>X</b>			<b>S</b>	<b>156.150</b>		<b>U.S. Government Only, Coast Guard</b>
04			X	D	156.200	160.800	Public Correspondence (Marine Operator), Port operation, ship movement
04A		X		S	156.200		Pacific coast: Coast Guard, East Coast: Commercial fishing
05			X	D	156.250	160.850	Public Correspondence (Marine Operator), Port operation, ship movement
05A	X	X		S	156.250		Port operation. VTS in Seattle
06	X	X	X	S	156.300		Inter-ship Safety
07			X	D	156.350	160.950	Public Correspondence (Marine Operator), Port operation, ship movement
07A	X	X		S	156.350		Commercial
08	X	X	X	S	156.400		Commercial (Inter-ship only)
09	X	X	X	S	156.450		Boater Calling channel, Commercial & Non-commercial (Recreational)
10	X	X	X	S	156.500		Commercial
11	X	X	X	S	156.550		Commercial. VTS in selected areas.
12	X	X	X	S	156.600		Port operation. VTS in selected areas.
13	X	X	X	S	156.650		Inter-ship Navigation Safety (Bridge-to-bridge)
14	X	X	X	S	156.700		Port operation. VTS in selected areas.
15	X			S	---	156.750	Environmental (Receive only)
15		X	X	S	156.750		Commercial, non-commercial, ship movement (1 W)
16	X	X	X	S	156.800		International Distress, Safety and Calling
17	X	X	X	S	156.850		State Controlled (1 W)
18			X	D	156.900	161.500	Port operation, ship movement
18A	X	X		S	156.900		Commercial
19			X	D	156.950	161.550	Port operation, ship movement
19A	X			S	156.950		US: Commercial
19A		X		S	156.950		Coast Guard
20	X	X	X	D	157.000	161.600	Canadian Coast Guard Only, International: port operations and shipment
20A	X			S	157.000		Port operation
21			X	D	157.050	161.650	Port operation, ship movement
<b>21A</b>	<b>X</b>	<b>X</b>		<b>S</b>	<b>157.050</b>		<b>U.S. Government Only, Canadian Coast Guard</b>
22			X	D	157.100	161.700	Port operation, ship movement
22A	X	X		S	157.100		US and Canadian Coast Guard Liaison and Maritime Safety Information Broadcasts announced on channel 16
23		X	X	D	157.150	161.750	Public Correspondence (Marine Operator)
<b>23A</b>	<b>X</b>			<b>S</b>	<b>157.150</b>		<b>U.S. Government Only</b>
24	X	X	X	D	157.200	161.800	Public Correspondence (Marine Operator)
25	X	X	X	D	157.250	161.850	Public Correspondence (Marine Operator)
26	X	X	X	D	157.300	161.900	Public Correspondence (Marine Operator)
27	X	X	X	D	157.350	161.950	Public Correspondence (Marine Operator)
28	X	X	X	D	157.400	162.000	Public Correspondence (Marine Operator)

VHF MARINE CHANNEL CHART							
CH	U	C	I	S/D	TX	RX	CHANNEL USE
60		X	X	D	156.025	160.625	Public Correspondence (Marine Operator)
61			X	D	156.075	160.675	Public Correspondence (Marine Operator), Port operation, ship movement
<b>61A</b>	<b>X</b>	<b>X</b>		<b>S</b>	<b>156.075</b>		<b>Public Coast: Coast Guard; East Coast: commercial fishing only</b>
62			X	D	156.125	160.725	Public Correspondence (Marine Operator), Port operation, ship movement
62A		X		S	156.125		Public Coast: Coast Guard; East Coast: commercial fishing only
63			X	D	156.175	160.775	Public Correspondence (Marine Operator), Port operation, ship movement
63A	X	X		S	156.175		Port Operation and Commercial. VTS in selected areas.
64		X	X	D	156.225	160.825	Public Correspondence (Marine Operator), Port operation, ship movement
<b>64A</b>	<b>X</b>	<b>X</b>		<b>S</b>	<b>156.225</b>		<b>Public Correspondence (Marine Operator), Port operation, ship movement</b>
65			X	D	156.275	160.875	Public Correspondence (Marine Operator), Port operation, ship movement
65A	X	X		S	156.275		Port Operations
66			X	D	156.325	160.925	Public Correspondence (Marine Operator), Port operation, ship movement
66A	X	X		S	156.325		Port Operations
67	X	X	X	S	156.375		US: Commercial. Used for Bridge-to-bridge com- munications in lower Mississippi River. Inter-ship only, Canada: Commercial fishing, S&R
68	X	X	X	S	156.425		Non-commercial (Recreational)
69	X	X	X	S	156.475		US: Non-commercial (Recreational), Canada: Commercial fishing only, International: Inter-ship, Port operations and Ship movement
70	X	X	X	S	156.525		Digital selective calling (voice communications not allowed)
71	X	X	X	S	156.575		US, Canada: Non-commercial (Recreational), International: Port operations and Ship movement
72	X	X	X	S	156.625		Non-commercial (Inter-ship only)
73	X	X	X	S	156.675		US: Port Operations, Canada: Commercial fish ing only, International: Inter-ship, Port operations and Ship movement
74	X	X	X	S	156.725		US: Port Operations, Canada: Commercial fishing only, International: Inter-ship, Port operations and Ship movement
75	X	X	X	S	156.775		Port Operations (Inter-ship only) (1W)
76	X	X	X	S	156.825		Port Operations (Inter-ship only) (1W)
77	X	X		S	156.875		Port Operations (Inter-ship only) (1W)
77			X	S	156.875		Port Operations (Inter-ship only)
78			X	D	156.925	161.525	Public Correspondence (Marine Operator), Port operation, ship-movement
78A	X	X		S	156.925		Non-commercial (Recreational)
79			X	D	156.975	161.575	Port operation and Ship movement
79A	X	X		S	156.975		Commercial

VHF MARINE CHANNEL CHART							
CH	U	C	I	S/D	TX	RX	CHANNEL USE
80			X	D	157.025	161.625	Port operation, ship movement
80A	X	X		S	157.025		Commercial
81			X	D	157.075	161.675	Port operation, ship movement
<b>81A</b>	<b>X</b>			<b>S</b>	<b>157.075</b>		<b>U.S. Government Only - Environmental protection operations.</b>
81A		X		S	157.075		Canadian Coast Guard Only
82			X	D	157.125	161.725	Public Correspondence (Marine Operator), Port operation, ship movement
<b>82A</b>	<b>X</b>	<b>X</b>		<b>S</b>	<b>157.125</b>		<b>U.S. Government Only, Canadian Coast Guard Only</b>
83		X		D	157.175	161.775	Canadian Coast Guard Only
83			X	D	157.175	161.775	Public Correspondence (Marine Operator)
<b>83A</b>	<b>X</b>	<b>X</b>		<b>S</b>	<b>157.175</b>		<b>U.S. Government Only, Canadian Coast Guard Only</b>
84	X	X	X	D	157.225	161.825	Public Correspondence (Marine Operator)
85	X	X	X	D	157.275	161.875	Public Correspondence (Marine Operator)
86	X	X	X	D	157.325	161.925	Public Correspondence (Marine Operator)
87		X	X	S	157.375		Port operation, ship movement
87A	X			S	157.375		Public Correspondence (Marine Operator)
88		X	X	S	157.425		Port operation, ship movement
88A	X			S	157.425		Commercial, Inter-ship Only
M1			X	S	157.850		U.K. version only
M2			X	S	161.425		U.K. version only

**NOTE:** Simplex channels, 3A, 21A, 23A, 61A, 64A, 81A, 82A and 83A CANNOT be lawfully used by the general public in U.S.A. waters.

## 11. INSTALLATION OF OPTION

### 11.1 FBA-42 ALKALINE BATTERY CASE

**FBA-42** is a battery tray that holds six AA size Alkaline batteries and is used with the **HX290E** transceiver. When the **FBA-42** is installed into the **HX290E** the radio can withstand immersion in water up to 1.5 m (approx. 5ft) for 30 minutes.

1. On the **FBA-42**, remove the battery tray cover. When it is hard to remove the battery tray cover, put a coin to the edge of the battery compartment (👉) then pry open the battery tray cover.
2. Slide the six AA size Alkaline batteries into the **FBA-42** Battery Case with the Negative (-) side of the batteries touching the spring connections inside the **FBA-42** Battery Case.
3. Attach the battery cover to the **FBA-42** Battery Case while being careful so that o-ring is not twisted.
4. Insert the **FBA-42** Battery Case into the battery compartment on the back of the **HX290E** transceiver while tilting the Belt Clip outward, then push the bottom side of the **FBA-42** Battery Case until the Battery Tray locks with the Battery Pack Latch.

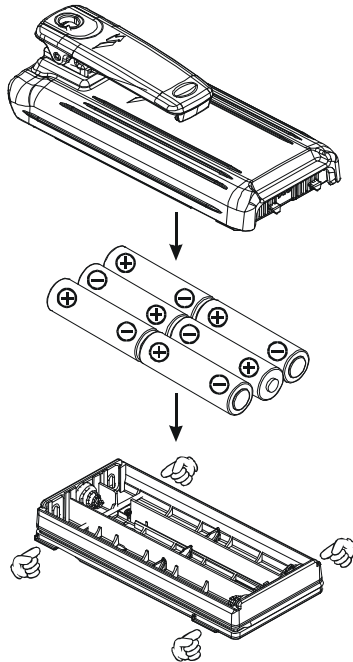

## 12. SPECIFICATIONS

Performance specifications are nominal, unless otherwise indicated, and are subject to change without notice.

### 12.1 GENERAL

<b>Frequency Ranges:</b>	156.025 MHz - 162.000 MHz
<b>Channel Spacing:</b>	25 kHz
<b>Frequency Stability:</b>	±10 ppm (−20 °C to +60 °C)
<b>Emission Type:</b>	16K0G3E
<b>Antenna Impedance:</b>	50 Ω
<b>Supply Voltage:</b>	7.4V DC, Negative Ground (Battery Terminal)
<b>Current Consumption:</b>	320 mA (Receive, Typical at AF MAX.) 50 mA (Standby) 1.6 A / 0.7 A (TX: 5 W / 1W)
<b>Operating Temperature:</b>	−20 °C to +60 °C
<b>Battery Type and Capacity:</b>	Lithium-Ion, 1170 mAh
<b>Waterproof Rating:</b>	JIS-8 / IPX8 (1.5 m for 30 minutes)
<b>Case Size (W x H x D):</b>	57 x 133 x 44 mm (w/o knob & antenna)
<b>Weight (Approx.):</b>	310 g (w/FNB-110LI, Belt Clip, & Antenna)

### 12.2 TRANSMITTER

<b>RF Power Output:</b>	5 W / 1 W (@7.4 V)
<b>Modulation Type:</b>	Variable Reactance
<b>Maximum Deviation:</b>	±5 kHz
<b>Spurious Emission:</b>	Less than 0.25 μW
<b>Microphone Impedance:</b>	2 kΩ

### 12.3 RECEIVER

<b>Circuit Type:</b>	Double-Conversion Superheterodyne
<b>Intermediate Frequencies:</b>	1st: 21.7 MHz, 2nd: 450 kHz
<b>Adjacent Channel Selectivity:</b>	70 dB
<b>Intermodulation:</b>	68 dB
<b>Hum &amp; Noise Ratio:</b>	40 dB
<b>Sensitivity:</b>	1 μV for 20 dB SINAD
<b>Selectivity:</b>	25 kHz (−70 dB)
<b>AF Output (Internal SP):</b>	700 mW @16 Ω for 10 % THD (@7.4 V)

*Measured in accordance with EN 301 178-2, EN 300 698-3, EN 301 843-2, and EN 60950-1.*



## **Declaration of Conformity**

We, Yaesu UK Ltd. declare under our sole responsibility that the following equipment complies with the essential requirements of the Directive 1999/5/EC.

Type of Equipment:	VHF Transceiver
Brand Name:	STANDARD HORIZON
Model Number:	HX290E
Manufacturer:	Vertex Standard Co., Ltd.
Address of Manufacturer:	4-8-8 Nakameguro Meguro-Ku, Tokyo 153-8644, Japan

### Applicable Standards:

This equipment is tested and conforms to the essential requirements of directive, as included in following standards.

Radio Standard:	EN 300 698-3
	EN 301 178-2
EMC Standard:	EN 301 843-2
Safety Standard:	EN 60950-1

The technical documentation as required by the Conformity Assessment procedures is kept at the following address:

Company: Yaesu UK Ltd.  
Address: Unit 12, Sun Valley Business Park, Winnall Close, Winchester  
Hampshire, SO23 0LB, U.K.

### **Disposal of your Electronic and Electric Equipment**

Products with the symbol (crossed-out wheeled bin) cannot be disposed as household waste.

Electronic and Electric Equipment should be recycled at a facility capable of handling these items and their waste byproducts.

In EU countries, please contact your local equipment supplier representative or service center for information about the waste collection system in your country.





**VERTEX STANDARD CO., LTD.**

4-8-8 Nakameguro, Meguro-Ku, Tokyo 153-8644, Japan

**VERTEX STANDARD**

**US Headquarters**

10900 Walker Street, Cypress, CA 90630, U.S.A.

**YAESU UK LTD.**

Unit 12, Sun Valley Business Park, Winnall Close  
Winchester, Hampshire, SO23 0LB, U.K.

**VERTEX STANDARD HK LTD.**

Unit 1306-1308, 13F., Millennium City 2, 378 Kwun Tong Road,  
Kwun Tong, Kowloon, Hong Kong

**VERTEX STANDARD (AUSTRALIA) PTY., LTD.**

Tally Ho Business Park, 10 Wesley Court, East Burwood, VIC, 3151

©Copyright 2011

VERTEX STANDARD CO., LTD.

All rights reserved.

No portion of this manual  
may be reproduced  
without the permission of  
VERTEX STANDARD CO., LTD.

Printed in China



E M O 4 5 N 1 5 0